

Features

- Ultra low leakage: nA level
- Operating voltage: 5V
- Low clamping voltage
- Up to four data lines and one power line protects
- JEDEC SOT-23 6L package
- Complies with following standards:
 - IEC 61000-4-2 (ESD) immunity test
 - Air discharge: $\pm 25\text{kV}$
 - Contact discharge: $\pm 20\text{kV}$
 - IEC61000-4-5 (Lightning) 5A (8/20 μs)
- RoHS Compliant

Dimensions SOT-23-6L

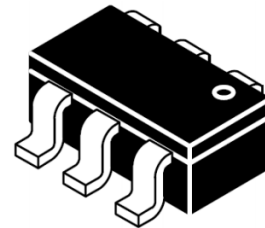

Applications

- USB 2.0 Power and Data lines protection
- Digital Visual Interface (DVI)
- Monitors and Flat Panel Displays
- Video Graphic Cards
- Notebook and PC Computers

Mechanical Characteristics

- Package: SOT-23 6L
- Lead Finish: Matte Tin
- Case Material: “Green” Molding Compound.
- Moisture Sensitivity: Level 3 per J-STD-020
- Terminal Connections: See Diagram Below
- Marking Information: See Below
- Quantity Per Reel: 3,000 pcs
- Device Marking: 0504A

Pin Configuration

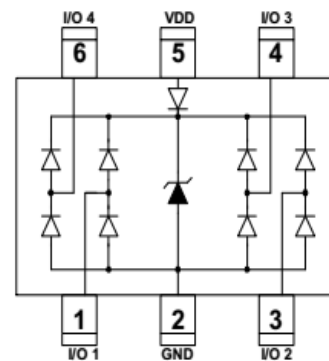

Absolute Maximum Ratings (Tamb=25°C unless otherwise specified)

Parameter	Symbol	Value	Unit
Peak Pulse Power (8/20 μs)	Ppp	75	W
ESD per IEC 61000-4-2 (Air)	V _{ESD}	± 25	kV
ESD per IEC 61000-4-2 (Contact)		± 20	
Operating Temperature Range	T _J	-55 to +125	°C
Storage Temperature Range	T _{STJ}	-55 to +150	°C

Electrical Characteristics (TA=25°C unless otherwise specified)

Parameter	Symbol	Test Condition	Min	Typ	Max	Unit
Reverse Working Voltage	V_{RWM}				5	V
Breakdown Voltage	V_{BR}	$I_T = 1\text{mA}$	6			V
Reverse Leakage Current	I_R	$V_{RWM} = 5\text{V}$			0.5	μA
Clamping Voltage	V_C	$I_{PP} = 1\text{A}$ (8 x 20 μs pulse)			10	V
Clamping Voltage	V_C	$I_{PP} = 5\text{A}$ (8 x 20 μs pulse)			15	V
Junction Capacitance	C_J	$V_R = 0\text{V}$, $f = 1\text{MHz}$		0.8		pF

Typical Performance Characteristics ($T_A=25^\circ\text{C}$ unless otherwise Specified)

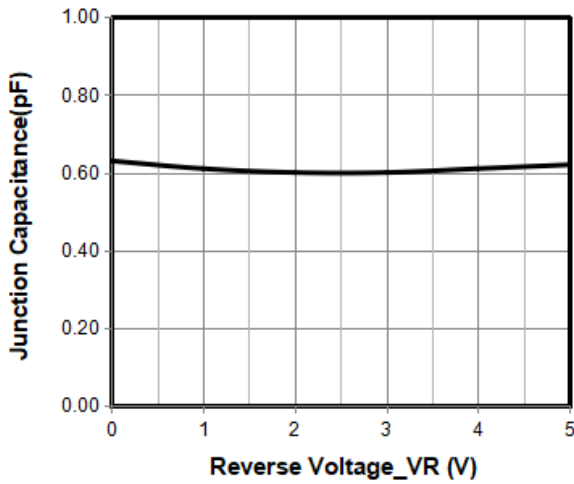

Junction Capacitance vs. Reverse Voltage

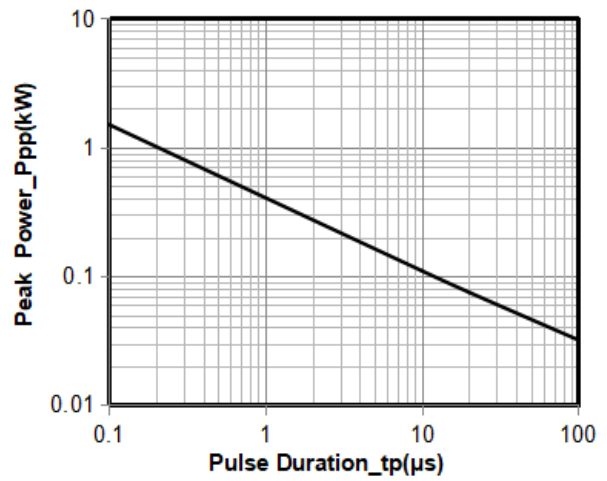

Peak Pulse Power vs. Pulse Time

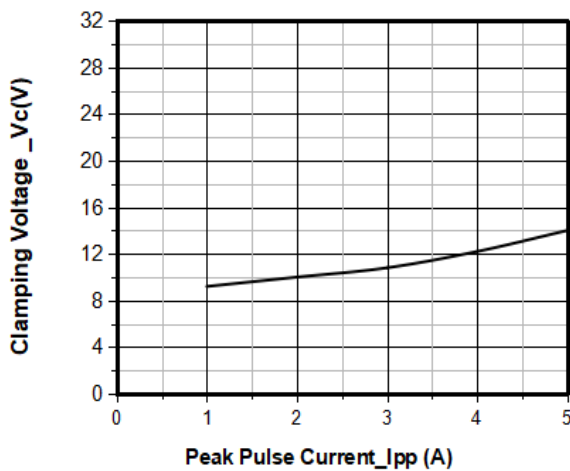

Clamping Voltage vs. Peak Pulse Current

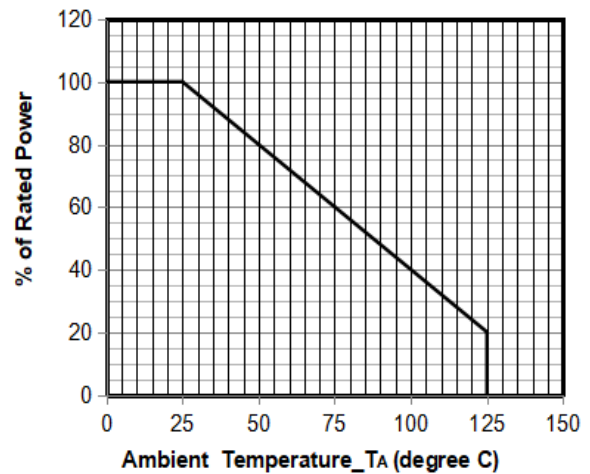

Power Derating Curve

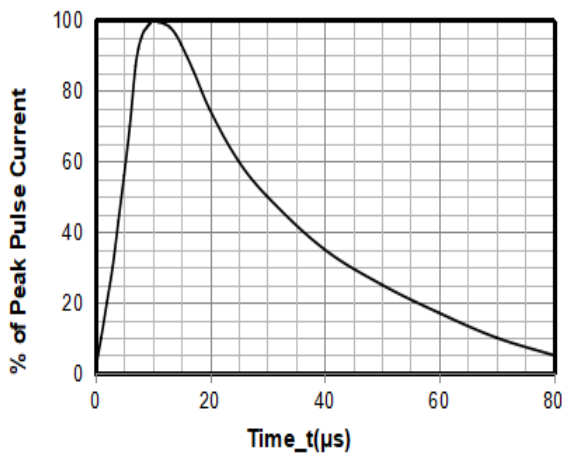

8 X 20μs Pulse Waveform

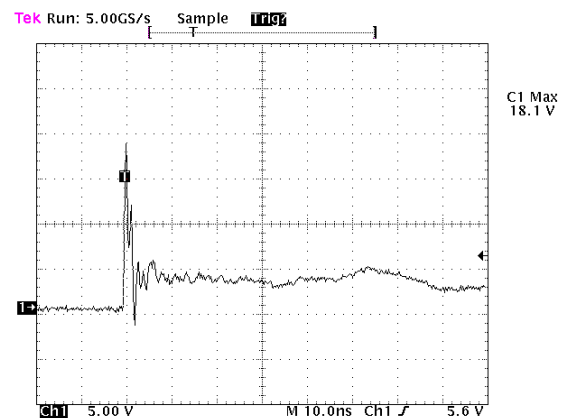

Note: Data is taken with a 10x attenuator

ESD Clamping Voltage

8 kV Contact per IEC61000-4-2

Typical Application

The SRV0504 is designed to protect four data lines from transient over-voltages by clamping them to fixed reference. When the voltage on the protected line exceeds the reference voltage (plus diode VF) the steering diodes are forward biased, conducting the transient current away from the sensitive circuitry. Data lines are connected at pins 1, 3, 4 and 6. The negative reference (REF1) is connected at pin 2. This pin should be connected directly to a ground plane on the board for best results. The path length is kept as short as possible to minimize parasitic inductance. The positive reference (REF2) is connected at pin 5.

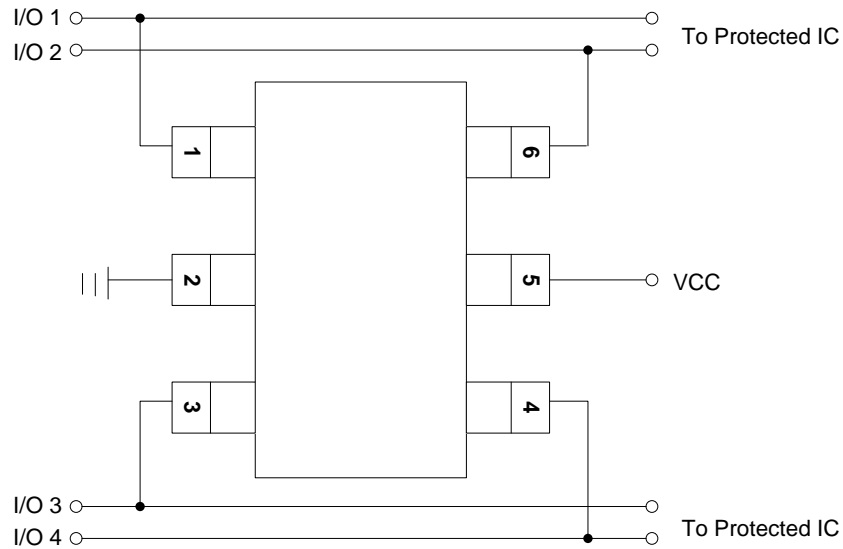

SRV0504 on USB 3.0 Port Application

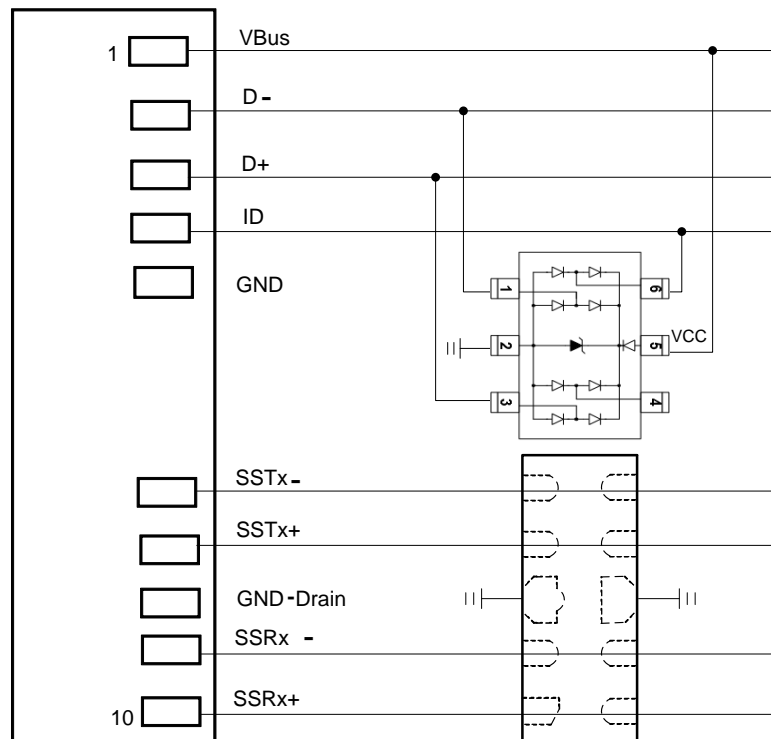

SRV0504 on HDMI Port Application

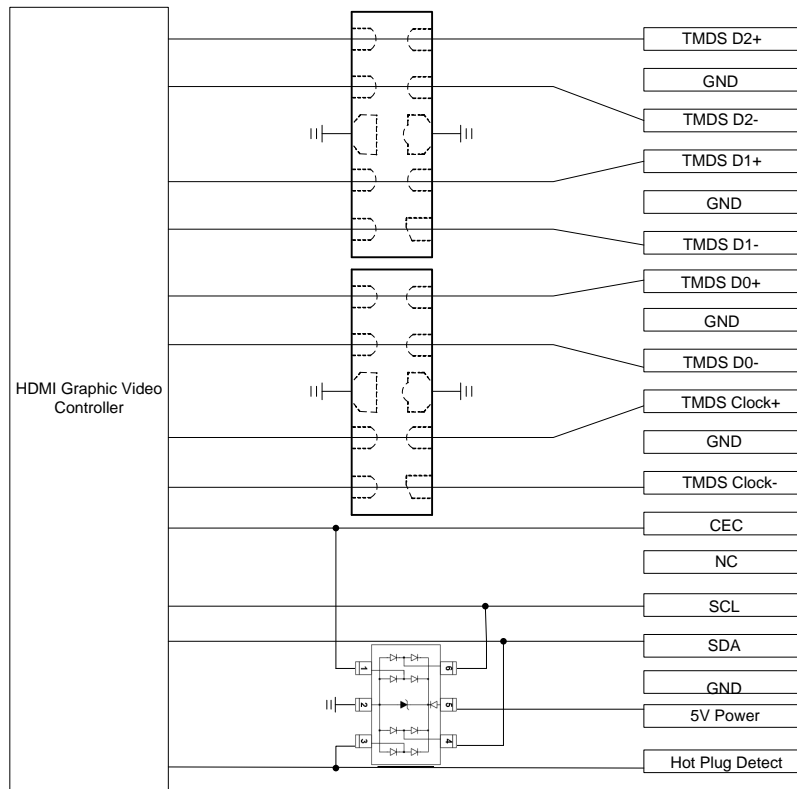

SRV0504 on USB Port Application

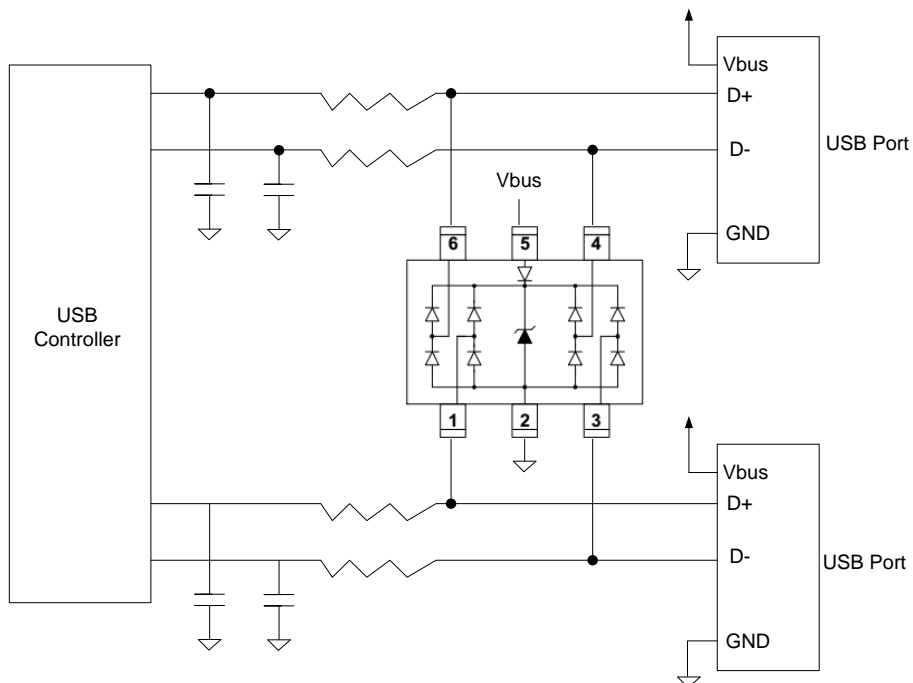

SOT-23-6L Package Outline & Dimensions

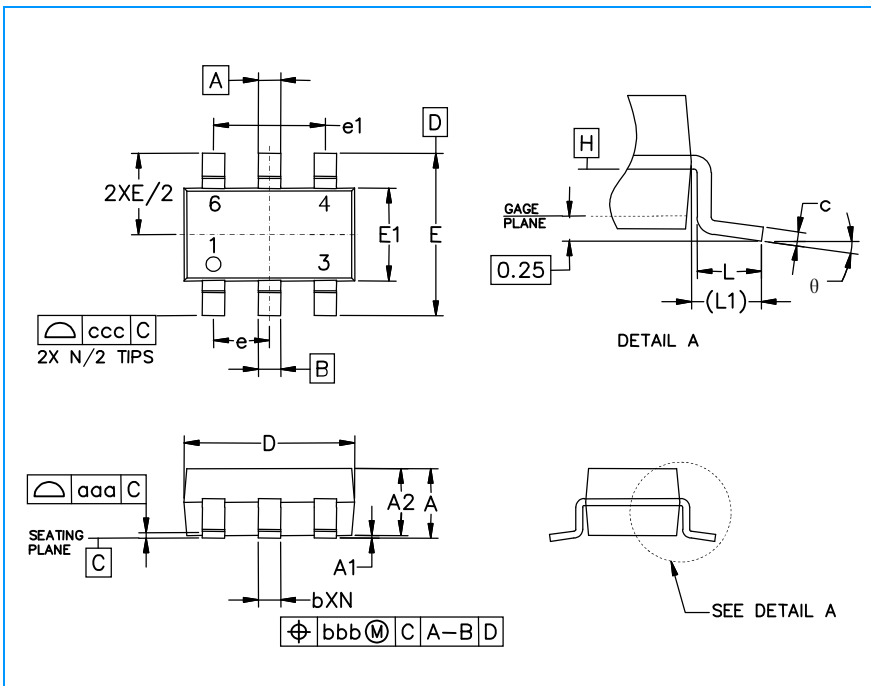

Symbol	Inches			Millimeters		
	Min.	Nom.	Max.	Min.	Nom.	Max.
A	0.035	-	0.057	0.90	-	1.45
A1	0.000	-	0.006	0.00	-	0.15
A2	0.035	0.045	0.051	0.90	1.15	1.30
b	0.010	-	0.020	0.25	-	0.50
c	0.003	-	0.009	0.08	-	0.22
D	0.110	0.114	0.122	2.80	2.90	3.10
E1	0.060	0.063	0.069	1.50	1.60	1.75
E	0.110 BSC			2.80 BSC		
e	0.037 BSC			0.95 BSC		
e1	0.075 BSC			1.90 BSC		
L	0.012	0.018	0.024	0.30	0.45	0.60
L1	(0.024)			(0.60)		
theta	0°	-	10°	0°	-	10°
aaa	0.004			0.10		
bbb	0.008			0.20		
ccc	0.008			0.20		

Soldering Footprint

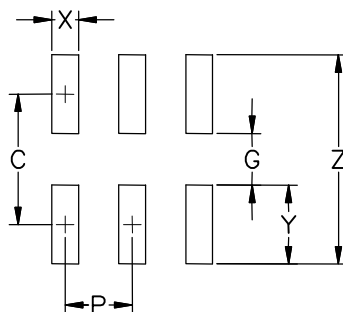

Symbol	Inches	Millimeters
C	(0.098)	(2.50)
G	0.055	1.40
P	0.037	0.95
X	0.024	0.60
Y	0.043	1.10
Z	0.141	3.60

NOTICE

Leiditech reserves the right to make modifications, enhancements, improvements, corrections or other changes without further notice to any product herein. Leiditech does not assume any liability arising out of the application or use of any product described herein.

Shanghai Leiditech Electronic Co., Ltd
 Email: sale1@leiditech.com
 Tel : +86- 021 50828806
 Fax : +86- 021 50477059