

Advanced-Failsafe, low slew-rate, +15kV ESD protection, 10Mbps rate transmission RS-485 Transceiver SP3485

Overview

The SP3485 is a high-speed transceiver for half-duplex communication for RS-485/RS-422 communication that contains a driver and a receiver.

The SP485 has fail-safe circuit. The low slew rate driver reduces EMI and back-off due to improper termination matching cables and achieves up to 10Mbps Error-free data transmission. With 15kV ESD protection.

SP3485 are rated for industrial (-40 to +85°C) operating temperatures. Receivers have exceptionally high input impedance, which places only 1/8th the standard load on a shared bus. Up to 128 transceivers may coexist while preserving full signal margin.

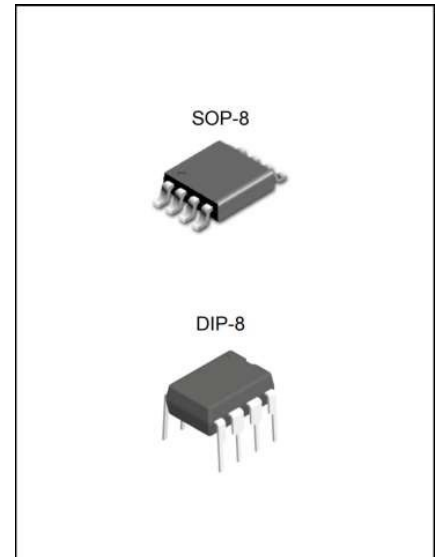

Features

- The I/O pins are protected against electrostatic discharge: $\pm 15\text{kV}$ HBM
- All other pins are protected against 3 levels of electrostatic discharge (ESD): $\pm 8\text{kV}$ HBM
- up to 128 devices on the bus
- +5V operating voltage (+3.3V supply, transmission rate maximum recommended 500Kbps).
- With slope limiting function, the maximum data rate is 10Mbps
- Weak current shutdown mode operating current: 1nA
- Current limiting and thermal shutdown for driver overload protection
- Package: SOP8, DIP8

Application

- Smart Instrumentation
- Industrial process control
- Building automation networks
- Motor control
- EMI sensitive transceiver applications

Ordering information

Type	Package	Packaging	MPQ
SP3485	SOP8	Reels	3500PCS

Block diagram

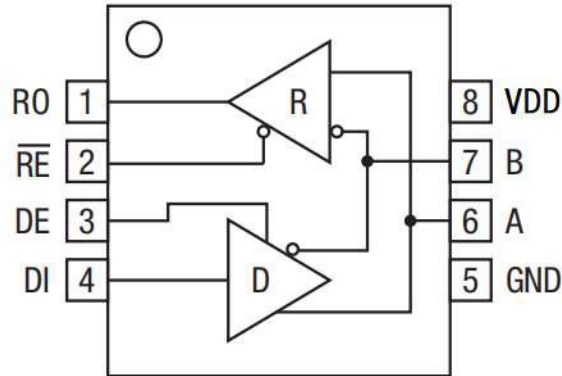

Pin description

Pins	Symbol	Function	attribute
1	RO	Receiver output: IF $A-B \geq -0.05V$, RO is high; IF $A-B \leq -0.2V$, RO is low; IF A and B are dangling or short, RO is also high.	O
2	\overline{RE}	Receiver output enable: \overline{WHEN} RE is low, RO is enabled; \overline{When} RE is high, RO is at high impedance.	I
3	DE	Driver output enable: Enable DE higher, the output of the driver, Y and Z, are enabled; they are at high impedance when DE are low.	I
4	DI	Driver input: DI is low, A is low, B is high; DI is high, A is high, B is low;	I
5	GND	Earth	
6	A	The input of the receiver and the output of the driver.	I/O
7	B	The input of the receiver and the output of the driver.	I/O
8	VDD	Power supply	

Function Tables

The SP3485 high speed half-duplex transceiver consists of a driver and receiver with a 1/8 unit load input impedance and up to 128 transceivers on the bus.

RECEIPT

Input			Output
\overline{RE}	DE	A - B	RO
L	X	$\geq -0.05V$	H
L	X	$\leq -0.2V$	L
L	X	Open/shorted	H
H	H	X	Z
H	L	X	Z

TRANSMISSION

Input			Output	
\overline{RE}	DE	DI	B	A
X	H	H	L	H
X	H	L	H	L
L	L	X	Z	Z
H	L	X	Z	

Absolute Maximum Ratings

Unless otherwise specified, $T_{amb} = 25\text{ }^{\circ}\text{C}$

Parameter	Symbol	Value	Unit
Supply voltage	V_{DD}	-0.3~7	V
Limit input/output voltage	V_{IN}/V_{OUT}	GND-0.3~ $V_{DD}+0.3$	V
A/B limit input/output voltage	$V_{IN\ A/B}/V_{OUT\ A/B}$	-13~13	V
Operating ambient temperature	T_{amb}	-40~85	$^{\circ}\text{C}$
Storage temperature	T_{stg}	-65~150	$^{\circ}\text{C}$

DC electrical characteristics

($V_{CC} = 5V \pm 5\%$, $T_A = T_{MIN}$ to T_{MAX} , unless otherwise noted.) (Notes 1, 2)

PARAMETER	SYMBOL	CONDITIONS	MIN	TYP	MAX	UNITS
Differential Driver Output (no load)	V_{OD1}				V_{DD}	V
Differential Driver Output (with load)	V_{OD2}	$R = 50\Omega$ (RS-422) ⁽¹⁾	2			V
		$R = 27\Omega$ (RS-485) ⁽¹⁾	1.8			
Change in Magnitude of Driver Differential Output Voltage for Complementary Output States	ΔV_{OD}	$R = 27\Omega$ or 50Ω ⁽¹⁾		0.01	0.2	V
Driver Common-Mode Output Voltage	V_{OC}	$R = 27\Omega$ or 50Ω ⁽¹⁾			3	V
Change in Magnitude of Driver Common-Mode Output Voltage for Complementary Output States	ΔV_{OC}	$R = 27\Omega$ or 50Ω ⁽¹⁾		0.01	0.2	V
Input High Voltage	V_{IH1}	DE, DI, \overline{RE}	2.0			V
Input Low Voltage	V_{IL1}	DE, DI, \overline{RE}			0.8	V
Input Current	I_{IN1}	DE, DI, \overline{RE}			± 2	μA
Input Current (A, B)	I_{IN2}	DE = 0V; $V_{CC} = 0V$ or $5.25V$,	$V_{IN} = 12V$		150	μA
			$V_{IN} = -7V$	-150		
Driver Output Short-Circuit Current	I_{OD1}	$-7V \leq V_{OUT} \leq V_{DD}$	-100			mA
		$0V \leq V_{OUT} \leq 12V$			100	mA
		$0V \leq V_{OUT} \leq V_{DD}$	± 25			mA

Receiver Differential Threshold Voltage	V_{TH}	$-7V \leq V_{CM} \leq 12V$	-0.2		-0.05	V
Receiver Input Hysteresis	ΔV_{TH}			40		mV
Receiver Output High Voltage	V_{OH}	$I_O = -4mA$, $V_{ID} = -50mV$	$V_{DD}-1$			V
Receiver Output Low Voltage	V_{OL}	$I_O = 4mA$, $V_{ID} = -200mV$			0.4	V
Three-State (high impedance) Output Current at Receiver	I_{OZR}	$0.4V \leq V_O \leq 2.4V$			± 1	μA
Receiver Input Resistance	R_{IN}	$-7V \leq V_{CM} \leq 12V$	96			k Ω
Receiver Short-Circuit Current	I_{OSR}	$0V \leq V_O \leq V_{CC}$	± 7		± 100	mA

No-Load Supply Current	I_{CC}	No Load $\overline{RE} = DI = GND$ or V_{DD}	DE = V_{DD}		450	900	μA
			DE = GND		450	600	μA

Transmission characteristics

Unless otherwise specified, $V_{DD} = 5V$ 5% and $T_{amb} = 25\text{ }^{\circ}C$

PARAMETER	SYMBOL	CONDITIONS	MIN	TYP	MAX	UNITS
Features slope limiting						
Drive input to Output	t_{DPLH}	$R_{DIFF}=54\Omega$, $C_{L1}=C_{L2}=100pF^{(2)}$		30	60	ns
Drive input to Output	t_{DPHL}	$R_{DIFF}=54\Omega$, $C_{L1}=C_{L2}=100pF^{(2)}$		30	60	ns
$ t_{DPLH}-t_{DPHL} $	t_{DSKEW}	$R_{DIFF}=54\Omega$, $C_{L1}=C_{L2}=100pF^{(2)}$			20	ns
Drive up and down Time	t_{DR}, t_{DF}	$R_{DIFF}=54\Omega$, $C_{L1}=C_{L2}=100pF^{(2)}$		30		ns
Maximum data transfer rate	f_{MAX}			10		Mbps
Drive enable delay	t_{DZH}	$C_L=100pF, S2$ CLOSED ⁽³⁾			70	ns
Drive enable delay	t_{DZL}	$C_L=100pF, S1$ CLOSED ⁽³⁾			70	ns
Drive shutdown delay	t_{DLZ}	$C_L=15pF, S1$ CLOSED ⁽³⁾			70	ns
Drive shutdown delay	t_{DHZ}	$C_L=15pF, S2$ CLOSED ⁽³⁾			70	ns
Receiver input and output Delay	t_{RPLH}	$ V_{ID} \geq 2.0V$ Rise and fall time $\leq 15ns^{(4)}$.		90	250	ns
Receiver input and output Delay	t_{RPHL}			90	250	ns
$ t_{RPLH}-t_{RPHL} $	t_{RSKD}	$ V_{ID} \geq 2.0V$ Rise and fall time $\leq 15ns^{(4)}$.		30		ns
Receiver enable delay	t_{RZL}	$C_L=100pF, S1$ CLOSED ⁽⁵⁾		30	70	ns
Receiver enable delay	t_{RZH}	$C_L=100pF, S2$ CLOSED ⁽⁵⁾		30	70	ns
Receiver shutdown delay	t_{RLZ}	$C_L=100pF, S1$ CLOSED ⁽⁵⁾		30	70	ns
Receiver shutdown delay	t_{RHZ}	$C_L=100pF, S2$ CLOSED ⁽⁵⁾		30	70	ns
Shutdown mode enable time	t_{SHDN}			200	600	ns

Notes:

- (1) The test circuit is shown in Figure 1
- (2) The test circuit is shown in Figure 2
- (3) The test circuit is shown in Figure 3
- (4) The test circuit is shown in Figure 4
- (5) The test circuit is shown in Figure 5

Test circuit

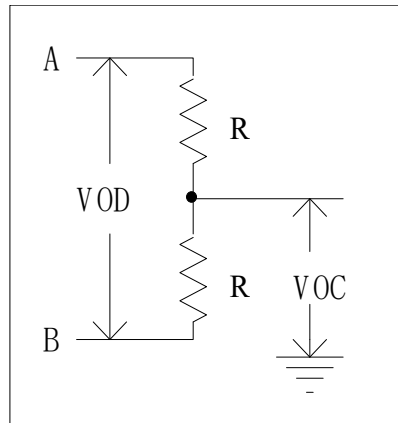

Figure 1 Drive DC Test

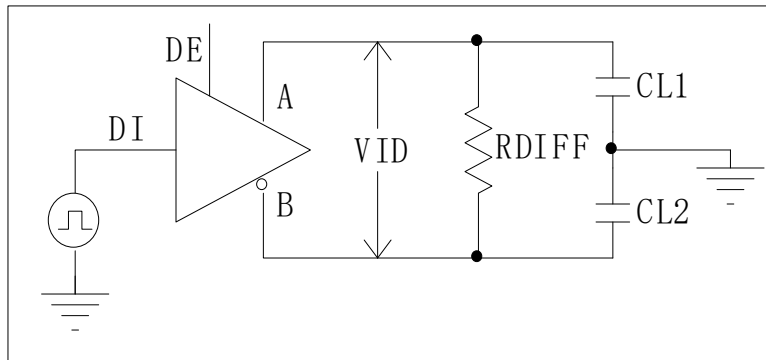

Figure 2 Driver Timing Test Circuit

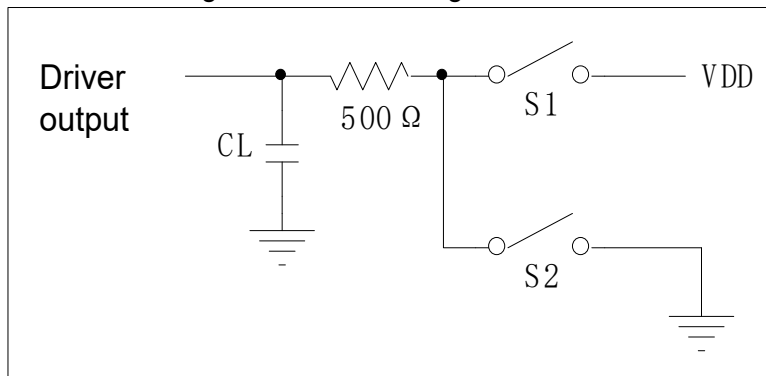

Figure 3 Drive enable/OFF timing test

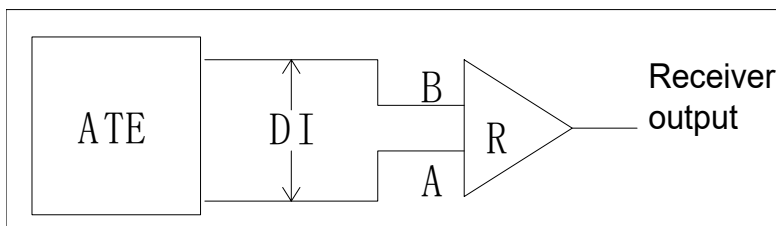

Figure 4 Receiver Delay Test Circuit

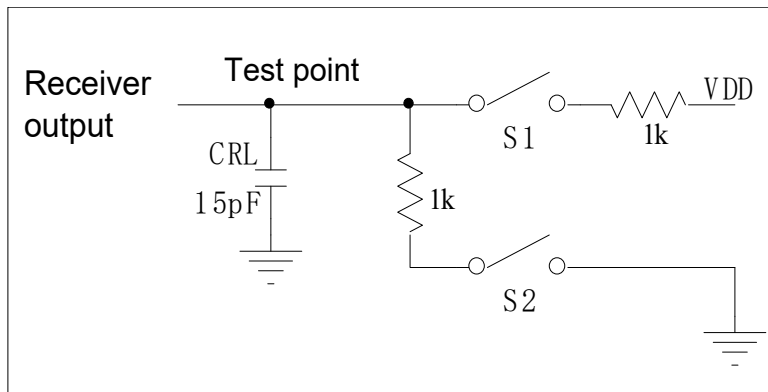

Figure 5 Receiver Enable/OFF Timing Test

Typical application circuit

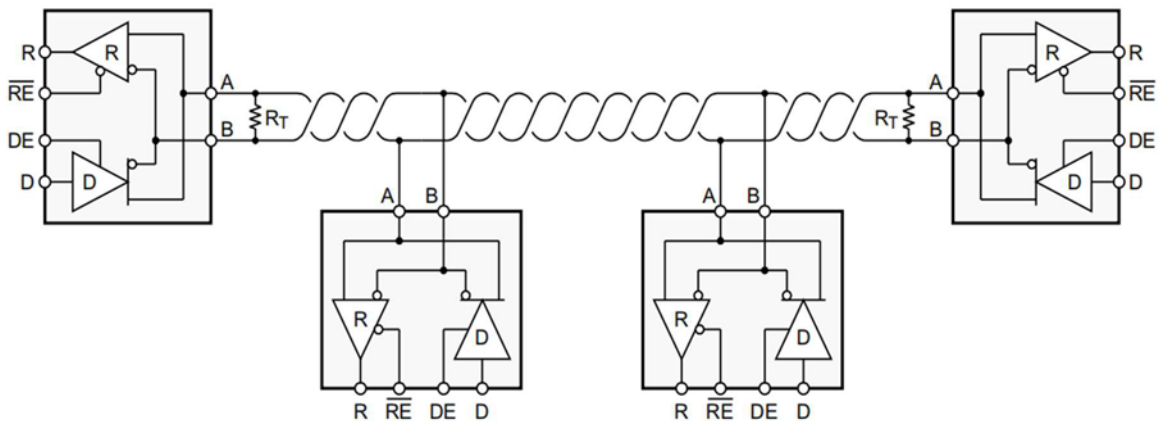
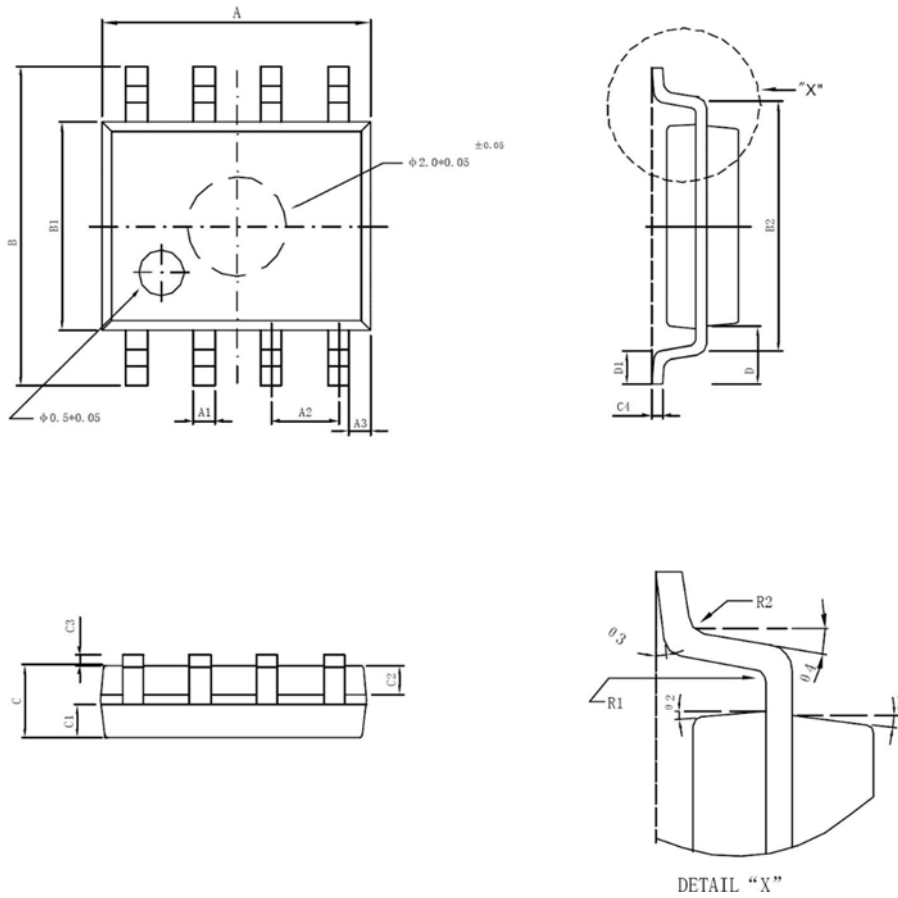

Figure 6 Typical Application Diagram

Transceivers are designed for bidirectional data communication on multi-point bus transmission lines. Figure 6 shows a typical network application power Road These devices can also be used as linear transponders with cable lengths longer than 4000 feet. In order to reduce reflection, terminal matching should be performed at both ends of the transmission line with their characteristic impedances, and the length of branch connections other than the trunk line should be as short as possible.

Package size (SOP8).



Marking	Min (mm)	Max (mm)	Marking	Min (mm)	Max (mm)
A	4.95	5.15	C3	0.10	0.20
A1	0.37	0.47	C4	0.20TYP	
A2	1.27TYP		D	1.05TYP	
A3	0.41TYP		D1	0.50TYP	
B	5.80	6.20	R1	0.07TYP	
B1	3.80	4.00	R2	0.07TYP	
B2	5.0TYP		θ_1	17°TYP	
C	1.30	1.50	θ_2	13°TYP	
C1	0.55	0.65	θ_3	4°TYP	
C2	0.55	0.65	θ_4	12°TYP	

Package size (DIP8)

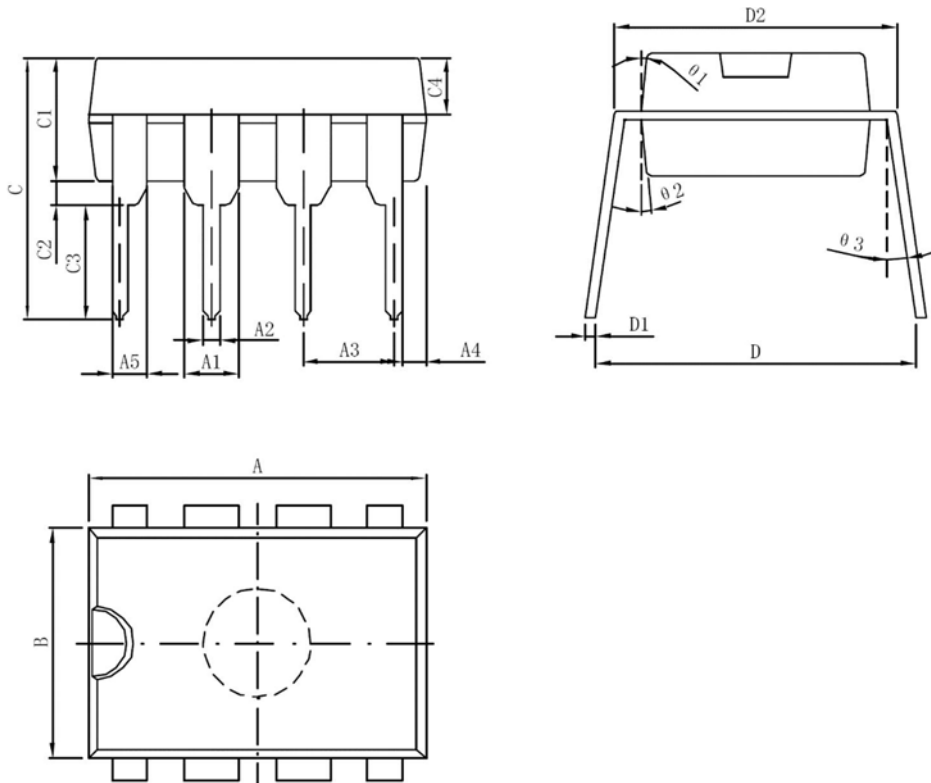

Marking	Min (mm)	Max (mm)	Marking	Min (mm)	Max (mm)
A	9.30	9.50	C2	0.50	
A1	1.524		C3	3.3	
A2	0.39	0.53	C4	1.57TYP	
A3	2.54		D	8.20	8.80
A4	0.66TYP		D1	0.20	0.35
A5	0.99TYP		D2	7.62	7.87
B	6.3	6.5	θ1	8°TYP	
C	7.20		θ2	8°TYP	
C1	3.30	3.50	θ3	5°TYP	